

HOT MELT APPLICATOR SYSTEM

FBS 45



ADDRESS : 325-5 DANGCHUNG-DONG  
GUNPO CITY, KYUNGKIDO, KOREA

TEL : +82-31-456-4190

FAX : +82-31-456-4191

E-Mail : [webmaster@phalbok.com](mailto:webmaster@phalbok.com)

<http://www.phalbok.com>

## ◆ Please make sure to observe it! ◆

© If not observed, failure and accident may occur.

### 1. Electric Specification

VAC                      Hz                      Kw

2. Do not turn the pump switch ON until it reached to the set temperature.
3. Switch off the power before the panel is opened.
4. Please make sure to read the operating manual before the installation and operation of the system.
5. At time of equipment maintenance and repair, switch off the MAIN power and wait until the temperature is dropped.
6. At time of equipment operation, do not use the pressure higher than required.  
(Do not operate the machine in a manner prohibited or not instructed in the manual.)
7. At time of filter change, change it after removing the pressure with the pump switch OFF.
8. As the surface of TANK and GUN is so hot and may cause burns, so never fail to wear a cotton gloves to touch it.
9. When the HOSE is connected to the TANK or GUN, the radius should be more than 200 mm, and fasten it rightly not to be twisted.

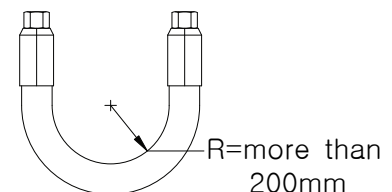

## ◆ Cleaning the tank ◆

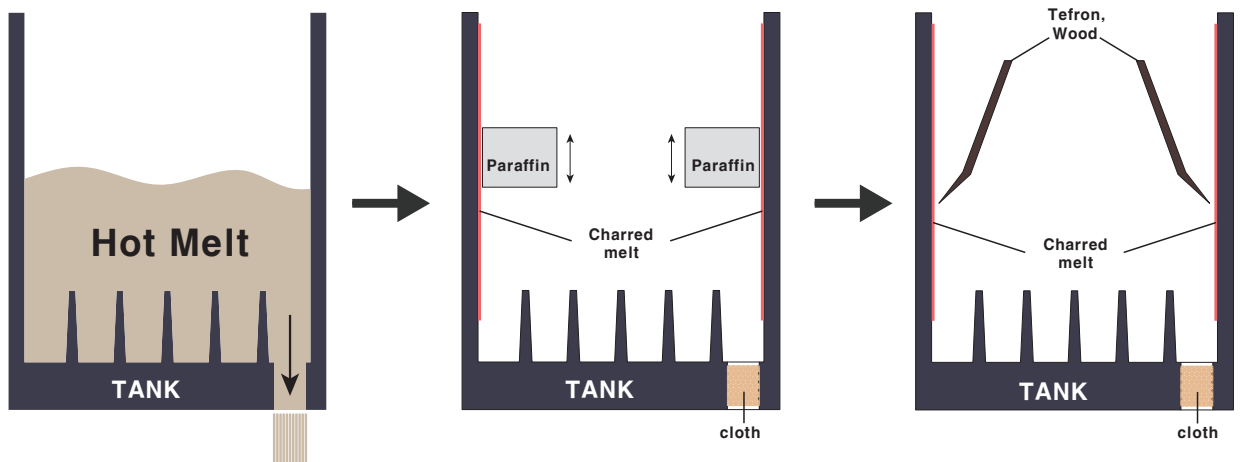

1. Discharge the remaining hot melt from the inside of the tank.
2. Stop the pump inlet port with a cloth, etc.
3. Remove the charred melt from the wall and grid inside of the tank using paraffin, etc.
4. If the charred melt is not removed with paraffin, scrub it using a safe tool (a wood knife, a teflon knife) that does not cause damage to the teflon coated inside of the tank.
5. Wipe the scraped carbide from the tank completely.
6. Separate the tank filter from the tank and clean it
7. Stop the tank filter blank and disengage the hose
8. After putting hot melt into the tank and melting it, discharge it until carbide is not coming out any more.
9. Replace the tank filter and the hose to complete the cleaning process of the tank.

◆ How to connect the power terminal ◆

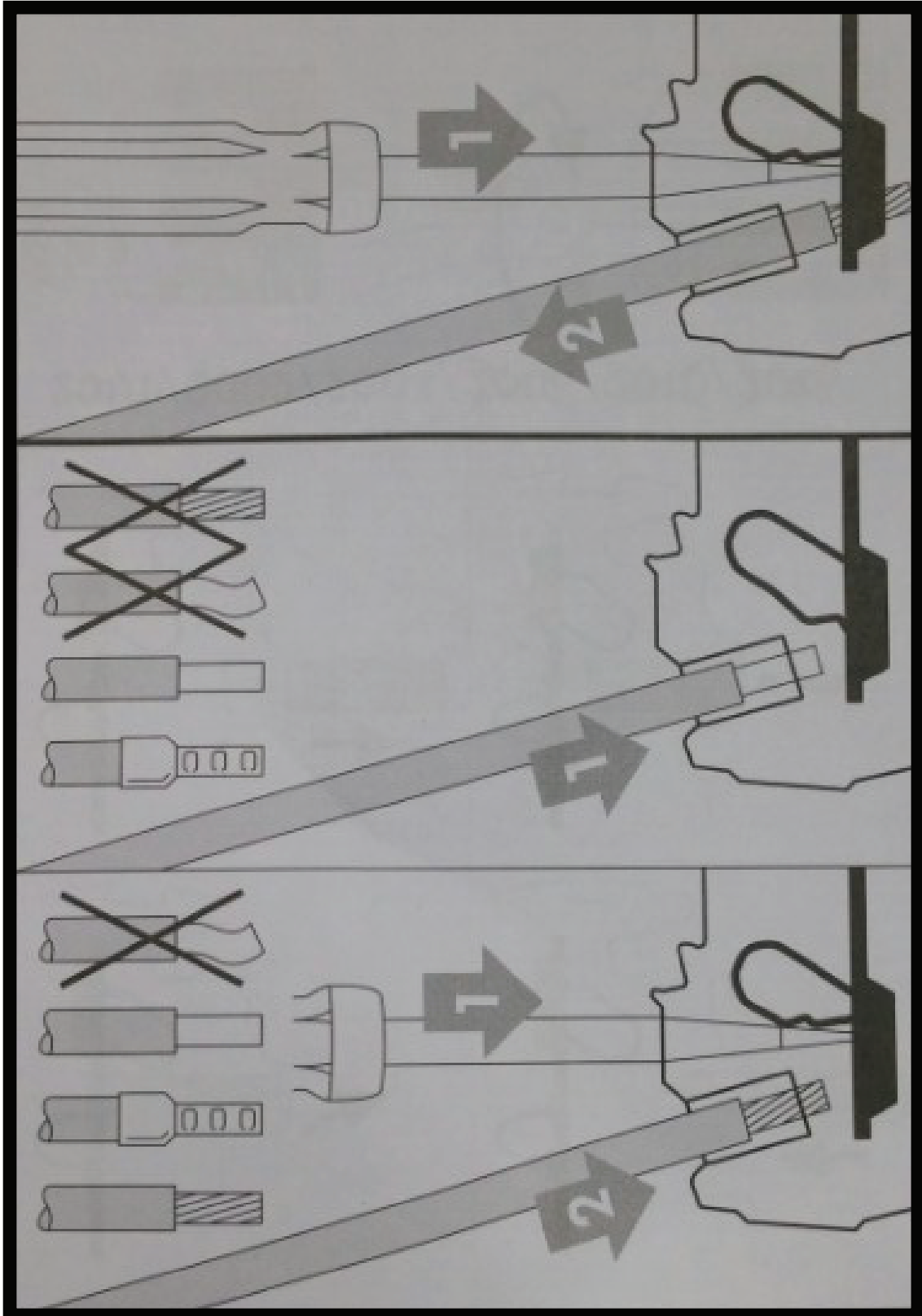

## – CONTENT –

1. Basic Requirements for safe use .....	1
(1) General Cares to be taken .....	1
(2) Mechanical operators Requirements .....	1
(3) Important caution for safety .....	2
(4) Label position .....	4
2. Outline of FBS-series Hot Melt Applicator .....	5
3. Installation of Hot Melt Applicator	
(1) Installation of Melt Unit .....	6
(2) Installation of Hot Melt Hose .....	6
4. Example of electric wiring	
(1) How to connect main power .....	8
(2) Interlock circuit between Hot Melt Applicator pump motor and main machine .....	9
5. Operation	
(1) Pre-operation care .....	11
(2) Name of each part .....	12
(3) Operating sequence .....	13
6. Precautions and inspection .....	18
7. Detailed specification of Model FBS-45 .....	19
8-1. Description of various electrical components .....	20
8-2. Specification and features of motor .....	22

---

## 9. PART LIST

(1) Disassembly drawing and explanation for FBS TANK .....	23
(2) Disassembly drawing and explanation for PUMP BLOCK .....	25
(3) Disassembly drawing and explanation for DENSITY VALVE .....	28
(3) Disassembly drawing and explanation for F.C.V VALVE .....	30

◆ CE LABEL

◆ Electrical Drawings

◆ Temperature controller (TCS-500) Series ◆

◆ GUN ◆

---

◆ MELT FLOW ◆

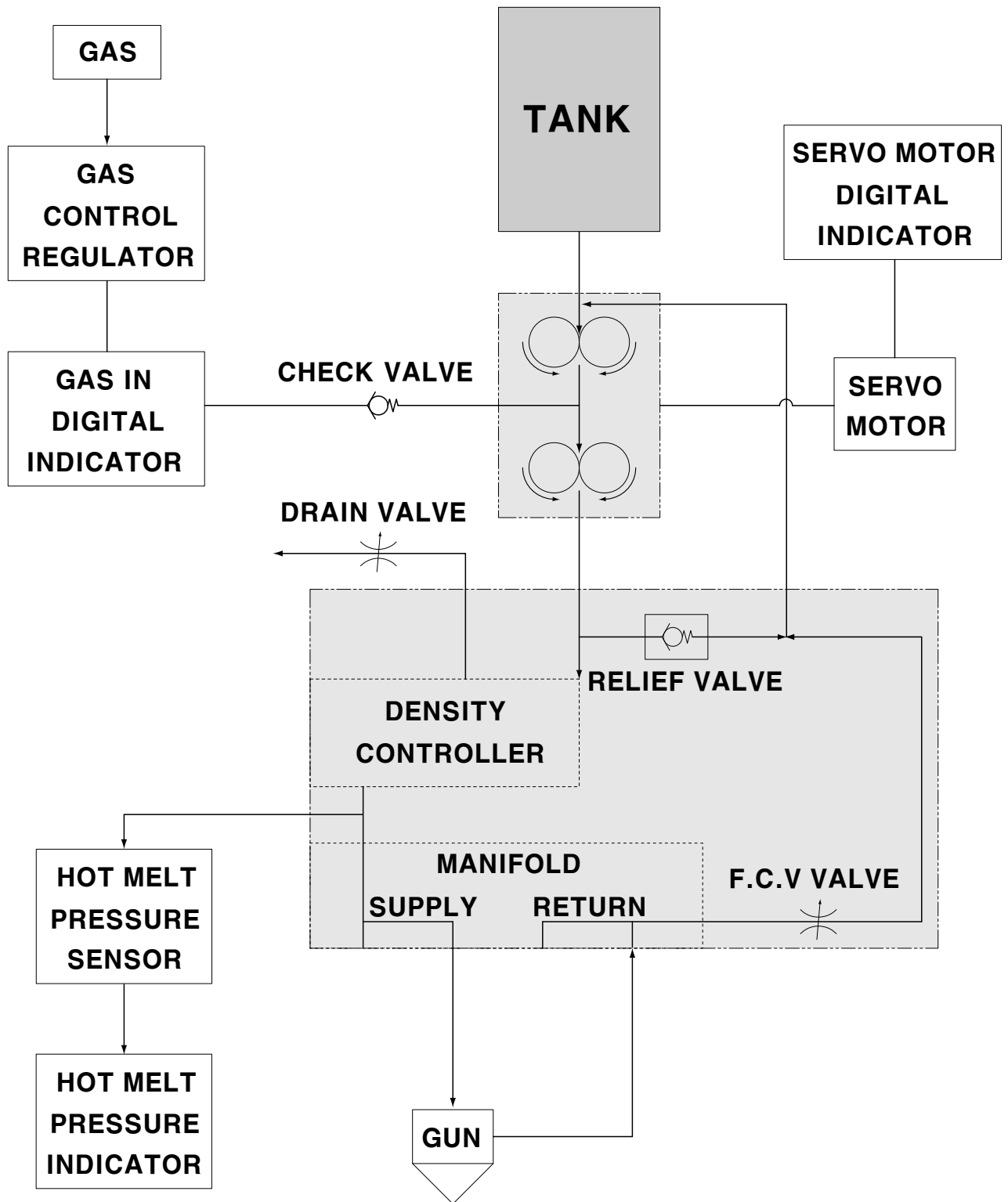

## 1. Basic Requirements for safe use

We, Phal Bok System, are very grateful for purchase of our products. Considering the fact that our HOT MELT APPLICATOR uses hot melt at high temperature, high pressure and high speed, please get familiarized with Service Manual for safety of operator and observe as required. Failure to observe Service Manual may cause bodily injuries and equipment damages.

### (1) General Cares to be taken

- \* Please be sure to get familiarized with Service Manual, prior to installation, operation and repair of HOT MELT APPLICATOR.
- \* Please have designated workers only be engaged in operation of the machine.
- \* When something goes wrong with the machine when in operation or it works abnormally, stop the machine immediately and contact Phal Bok System to get technical direction.
- \* Do not operate the machine in such a manner as prohibited or not instructed in Service Manual.
- \* We are entirely not responsible for any breakdown and bodily injuries caused by installation, operation and repair not conforming to the Service Manual. With respect to what is not specified in MANUAL, please inform us for confirmation.



It indicates first-hand exposure to danger  
Likely to cause death or serious injury.



It indicates potentially dangerous situation.  
Likely to cause serious injury or equipment failure. .



It indicates potentially dangerous situation. .  
Likely to cause mild injury or equipment failure.



It indicates necessary and useful information  
required for operation and repair.

### (2) Mechanical operators Requirements

- \* Workers to meet the following requirements are allowed to operate and repair the machine.
  - ① Qualified worker
  - ② Delegated worker
  - ③ Educated worker

## (3) Important caution for safety

### ◆ Transfer of equipment



- ⦿ Do not raise or transfer the machine without being supported by mechanical lift.

### ◆ Wearing protective equipment



- ⦿ When installing, operating and repairing HOT MELT APPLICATOR or working around it, please be sure to wear protective goggle, gloves (made of leather) and clothes.

### ◆ Danger of high pressure ejection



- ⦿ Ejection of high pressure melt resin is likely to cause injury like burn. Do not operate the machine in such a manner as prohibited or not instructed in Service Manual.

### ◆ Prohibition from operating the machine



- ⦿ Personnel without having professional education is not allowed to handle the machine.

### ◆ Safety cover



- ⦿ Stop operating the machine before opening cover.

◆ Grounding.



◆ Electrical hazard.



- ⦿ Before operation, close the machine with locking device.
- ⦿ Turn off power before approaching electrical equipment.

◆ Familiarity with service manual.



- ⦿ Before installation and operation of the system, get familiarized with service manual.

◆ Burn hazard (hand off, do not touch)



- ⦿ After cutting off power, wait to operate the machine until temperature will go down.

◆ Caution



- ⦿ Stop operating the machine before opening cover.
- ⦿ When replacing filter, remove pressure.
- ⦿ Do not touch the surface which is hot.
- ⦿ Failure to follow this instruction may cause burn hazard etc.

## (4) Label position

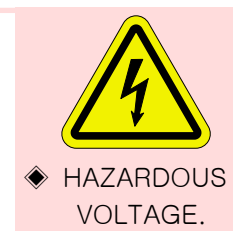
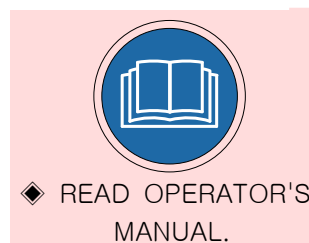
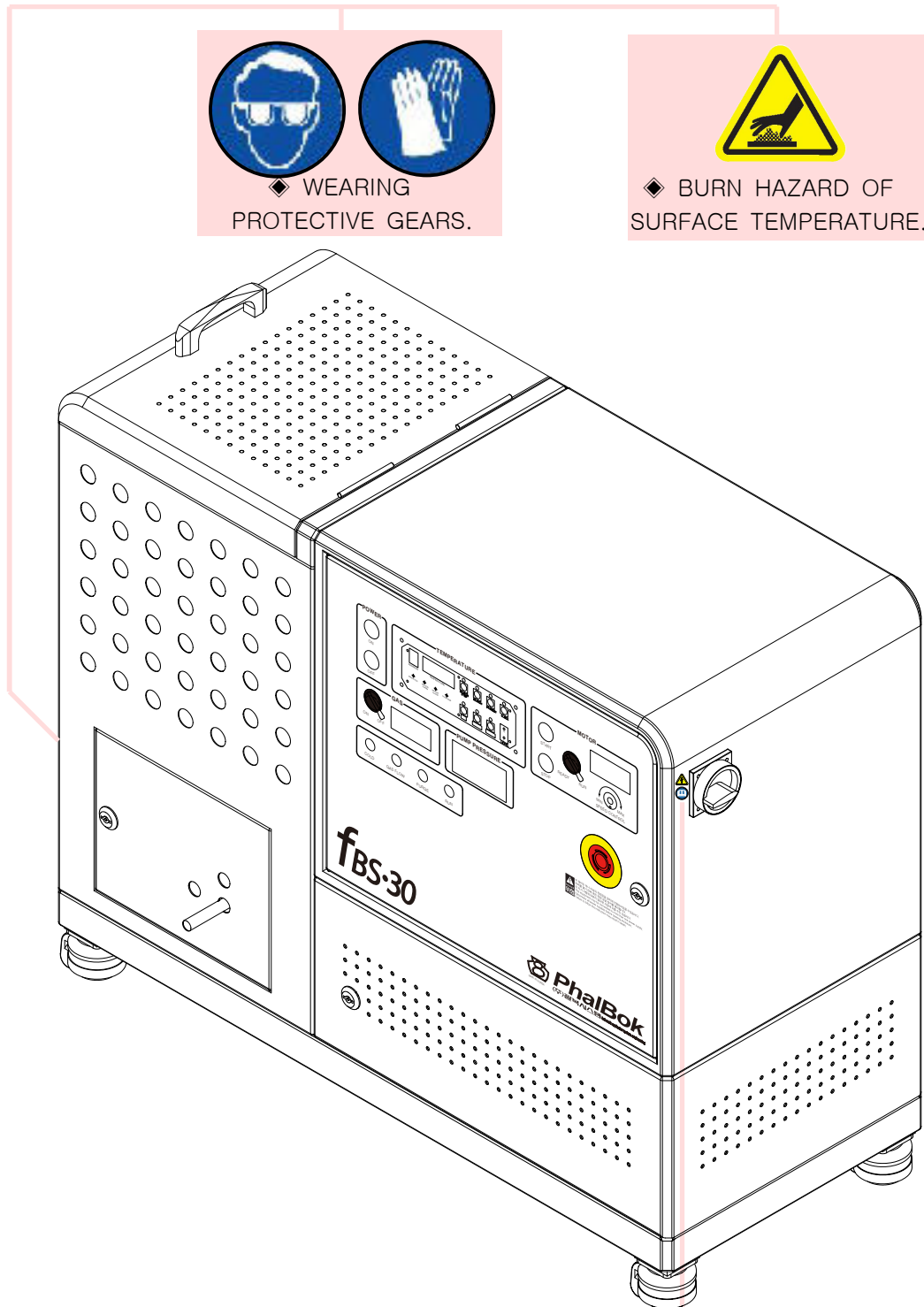

## 2. Outline of FBS-series Hot Melt Applicator

- \* FBS-series is made up of 2-speed gear pump unit, which melts the hot melt adhesives or thermoplastics, mix them with CO2 gas or N2 gas to foam in uniform magnification and to be discharged for various applications. This unit is designed to obtain a stable discharge volume and constant number of revolutions by using servo motor.
- \* The heating tank of FBS-series can be used for general hot melt adhesives of various shapes such as pellet, flat plate or block or decompressed hot melt adhesives but cannot be used for the hot melt adhesive that is rapidly aging by heat.
- \* As FBS-series has a simple mechanical structure and a high reliability, you can easily identify its troubles and repair them with the ordinary tools.

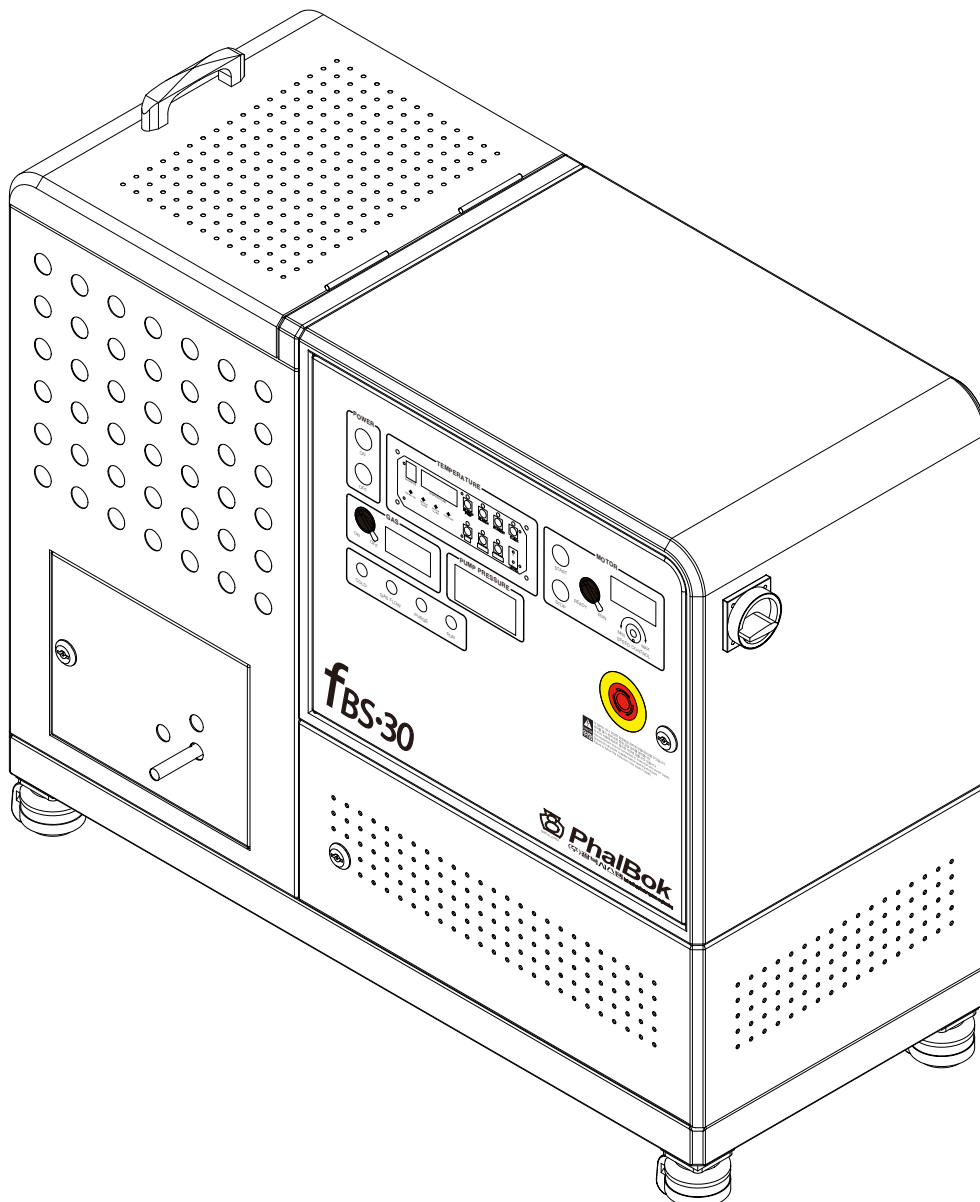

## (1) System of Fluid Pressure Part

- \* You can put a maximum of 30kg of hot melt adhesive in pellet, slug or block shapes into the tank of applicator. The applicator melts hot melt adhesive in the tank while it is in operation. The 2-speed gear pump is located at the bottom of the tank and driven by the servo motor directly connected to it. The melted hot melt adhesive is mixed with CO<sub>2</sub> or N<sub>2</sub> gas in the gear pump and, after its fluid pressure is raised by the pump, is discharged from the distribution port (outlet) of the pump block into the air through one or two heated supply hose and gun and returns to the low pressure from the fluid pressure of the system. As a result, gas locked in the inside rapidly inflates into small bubbles to make foam of hot melt adhesive.  
(As the pump block is sealed by O-ring from the tank and the pump and the discharge of the pump is affected by the gas volume of the system, the density controller keeps the rate of gas to hot melt adhesive at a constant level)
- \* Foam melt system makes the hot melt adhesive which has not been discharged into circulation system return to the pump block through one or several heated hoses. Hot melt is circulated to gear pump after passing through flow control valve (F.C.V). If the fluid pressure of the system is too high, the press relief valve is opened and the hot melt adhesive returns to the entrance of the pump through the press relief valve. The pressure sensor is mounted on the pump block to display the operational fluid pressure.

## (2) Gas Control System

- \* CO<sub>2</sub> gas or N<sub>2</sub> gas is supplied to the system from the gas cylinder. The decompression valve and pressure gauge is installed in order to control the pressure of gas before activating the solenoid valve and the solenoid valve is opened when the density controller gives a signal. The check valve is mounted on the pump block and prevents the hot melt adhesive from flowing backward to gas line even when the pump is worn down. The gas supplied by the gas control system is mixed with the hot melt adhesive sucked into the vacuum area created in the second of 2-speed pump.

## (3) Electrical System

- \* The temperature of the tank is detected by the thermostat at the bottom of the tank and can be controlled by TCS-500 (temperature controller) on the front panel of the applicator. For the safety sake, a limiter is installed to protect the unit from the unexpected damage by abnormal heating.

## 3. Installation of NINO-series Hot Melt Applicator

### (1) Installation of Melt Unit

- ① Hot Melt Tank should be installed horizontally at a place which is not affected by vibration and convenient for operation, and it should be assembled firmly by using the mounting holes on the ground.  
(You should install it firmly so that it does not topple over or move)
- ② Hot Melt Tank should be installed at a place where it is not affected by the wind.  
Example: a) avoid the place near the window where it is affected by the wind directly.  
b) avoid the place near the fan, air conditioner or control box fan etc.
- ③ Install Hot Melt Tank off the ground and keep the clearance of a certain distance between the bottom of Tank and the floor.  
(In order that you can protect the equipment when you wash the machine or the floor with water)

### (2) Installation of Hot Melt Hose

- ① Hose should be assembled or disassembled after Hot Melt is heated for melting.  
(If you bend hose within the bending radius of 200mm, the inside material or heater etc can be displaced or damaged)
- ② When you assemble or disassemble Hose, you may lift up or tilt the Tank only to the extent that Hot Melt does not spill over.
- ③ Be careful that Hose is not twisted when it is assembled or disassembled.
- ④ When you install Hose, you should allow a bending radius of 200mm at least.  
(If you try to bend Hose when Hot Melt is not melted, it can be damaged)
- ⑤ When you want hang Hose from the ceiling or upon the column, make sure that any part of Hose is not tightened or it hinders the radiation of heat. (For this, please use hose band)

## \*\*\*\* Instructions on how to install Hot Melt Hose \*\*\*\*

1) 1) Make sure that Hose is not bent in a radius of less than 200mm when you install it.

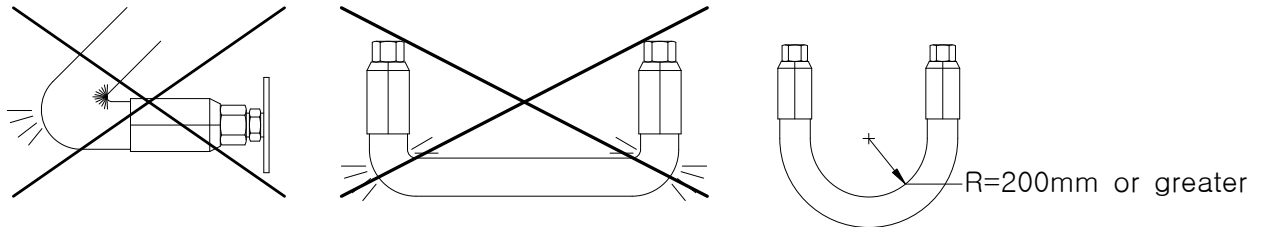

1) When you use more than 2 Hoses, the distance between them should be over 15mm.

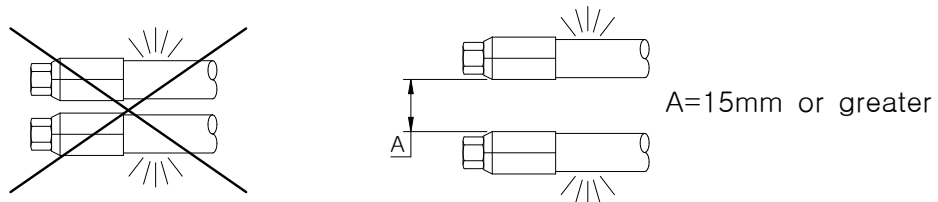

3) When you fasten any part of Hose, it should not be constricted or hinder the radiation of heat.

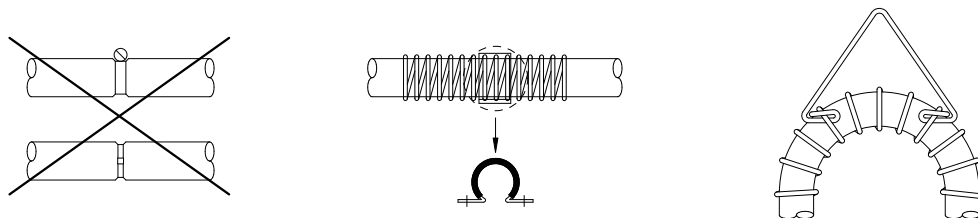

4) When you connect Hose with Tank or Hose and Gun, you should hold the nipples of both ends. Otherwise, Hose can be damaged or twisted.

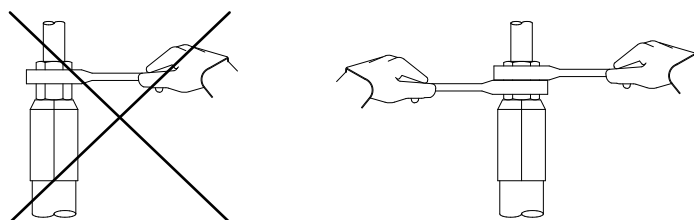

5) When you connect Hose, make sure to select the right type of nipple for the intended application.

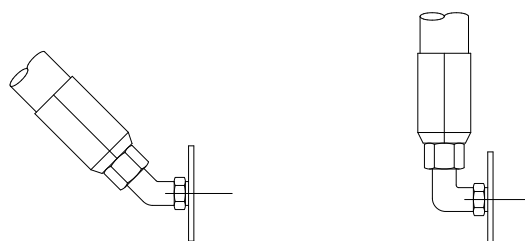

## 4. Example of Electric Wiring

### (1) Connection of main power

- ① NINO-SERIES should be supplied power in a Three-phase 3φ, 220vac, 60Hz, absolutely with grounding for safety's sake.
- ② Thickness of electrical wires to be connected with main power depends upon capacity of NINO-SERIES.
- ③ How to connect the main power

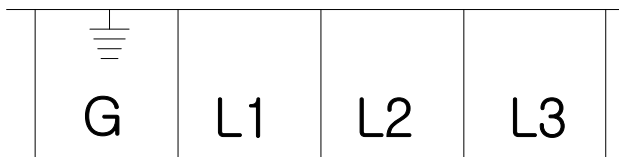

Connect 3Φ220VAC, 60Hz to L1, L2 and L3 and ground G terminal

### (2) Interlock Circuit between Hot Melt Applicator Pump Motor and Main Machine

- ① When you do an emergency stop of main machine or stop operation (for meal time or break time)  
By constituting an electric interlock circuit with pump motor, the safety is Secured, energy is saved and the service life is extended.
- ② Example of electric interlock circuit

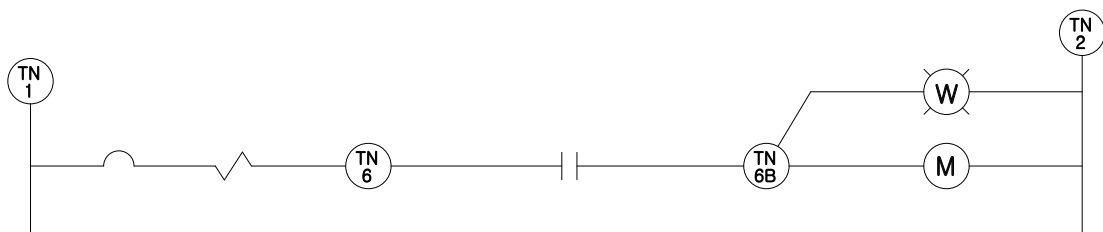

At the time of delivery, operation output contact is connected to  $\text{TN } 6$  and  $\text{TN } 6\text{B}$  .  
If you want to do motor interlock, please use operation contact.

### ③ Electric wiring of solenoid coil of auto gun

#### ◆ When you use solenoid coil 100VAC

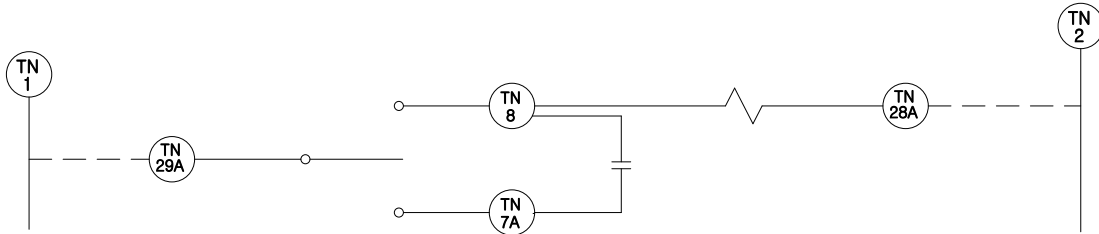

#### ◆ When you use single phase 110VAC

Connect a separate 110VAC power output to terminal block 29A and 28A.

Never fail to remove jumping wire if terminal block 1 and 29A, 2 and 28A are jumped.

#### ◆ When you use D.C. Driver

Connect output terminal no.3 and 4 of D.C. Driver to 29A and 28A of tank terminal and jump tank terminal no. 8 and 7A.

(Never fail to remove jumping wire if terminal block 1 and 29A, 2 and 28A are jumped.)

#### ◆ When you use solenoid coil 220VAC

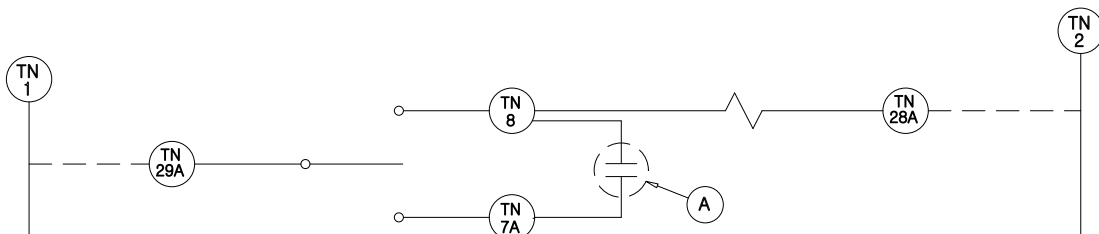

◆ Jump terminal no. 1 and 29A, no. 2 and 28A. Connect relay contact to A of machine.

#### ◆ When you use air solenoid coil 24VDC

◆ If the main machine supplies 24VDC, connect it directly to air solenoid coil terminal.

◆ When you use D.C Driver, connect D.C output of D.C output Driver terminal no.3 and 4 to air solenoid coil terminal and connect relay contact to D.C Driver terminal no. 6 and 8, or connect sensor output.

◆ When you have to operate at a high speed, or do the work with high pressure or high viscosity, D.C Driver is more desirable.

◆ You have to control solenoid coil of auto gun from the main machine.

## 5. Operation

### (1) What you have to check before operation

- ① Check the installation condition and electric circuit of tank, hose and gun before you start operation.
- ② Remove all the flammable or hazardous materials from the inside or surroundings of Hot Melt System Tank.
- ③ For the use of Hot Melt (adhesive), please follow the advice of the manufacturer.
- ④ After setting the temperature of tank, hose and gun, turn on the main power switch of Melt Unit. Normally auto gun has to be set at the temperature the manufacturer recommends; hose is set at 5~10°C lower temperature than gun; tank is set at 5~10°C lower temperature than hose.
- ⑤ After switch on the power, preheat for 30~60 minutes.  
Preheating time can vary depending upon the voltage, ambient temperature, type of hot melt adhesive (Base polymer such as EVA, Polyamide, Polyester, APP, Rubber etc). Choose the optimum preheating time.
- ⑥ Confirm that there is not foreign matter in the tank and fill the hot melt adhesive up to level of 5 cm below the top of tank. (containing the carbonization in the tank)
- ⑦ If you use different type of adhesive alternately (risk of being mixed with different type of adhesive) or put cleaning agent, you will run the risk of heat, flame, toxic gas, poor performance of adhesive, cross-linking. Therefore, follow the manufacturer's advice for alternate use or for the selection of cleaning agent.
- ⑧ The liquid or gas which is injected into the tank for the purpose of cleaning or preventing the carbonization should be non-flammable at the operation temperature.

### ◎ Caution and reference

- ① Excessive preheating should be avoided because the hot melt adhesive, at the designated application temperature, changes chemically little by little as time passes. (to delay the gelation and carbonization, and save energy)
- ② Fill the tank with the hot melt adhesive to the extent that it does not spill over.
- ③ Use the hot melt adhesive at a lowest possible temperature by referring to the temperature which the manufacturer has designated. (to prevent carbonization, and save energy)
- ④ Apply the minimum volume of hot melt adhesive for a job by adjusting flow control valve (to prevent the overloading of motor and wearing down of gear pump)

## (2) Name of each part

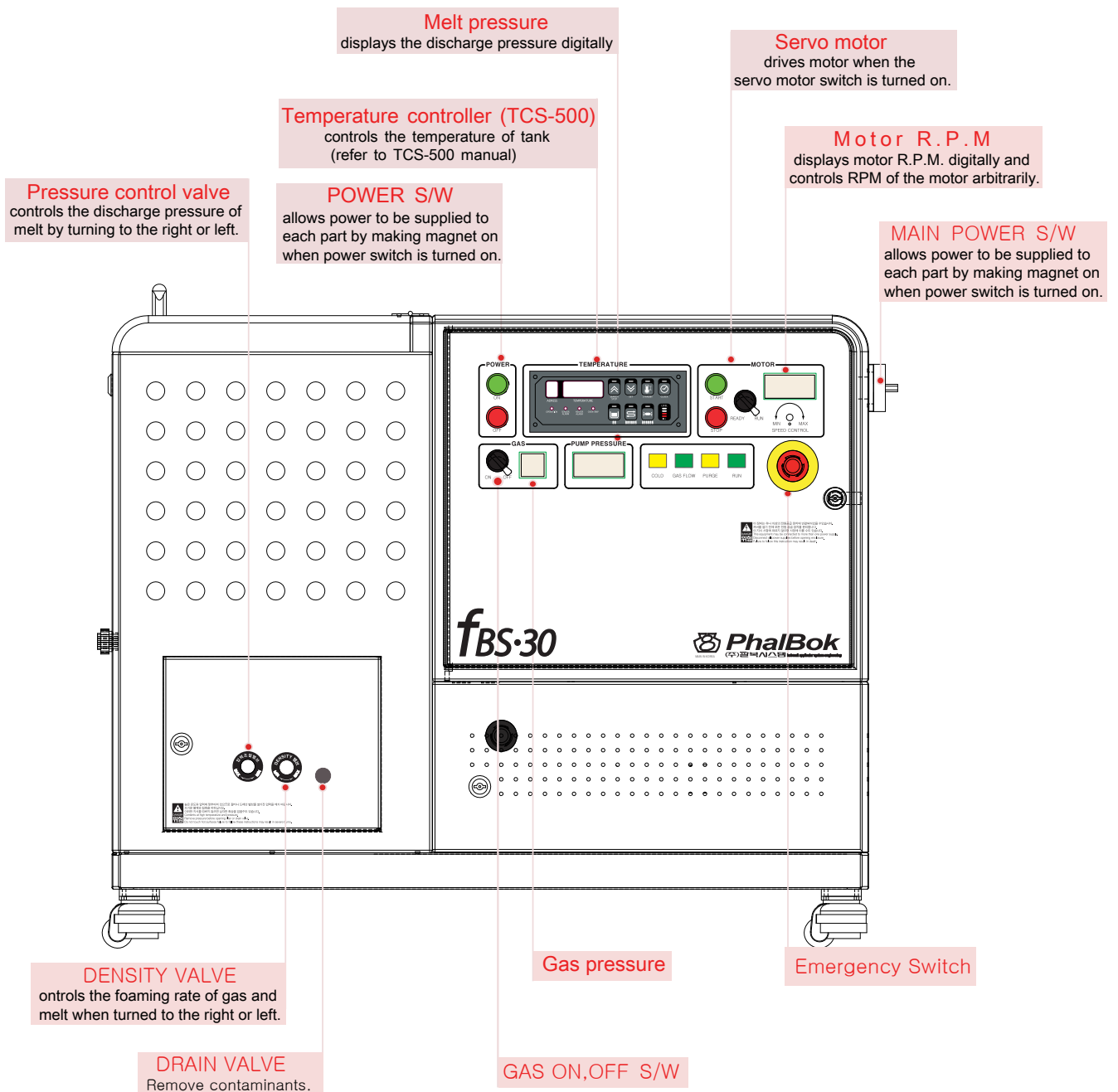

- will be lighted when the temperature goes below the setting temperature.
- will be lighted when gas is injected.
- will be lighted when motor switch is turned to 'Ready'
- will be lighted when motor switch is turned to 'Run'

## (3) Operation Sequence

### 1) Adjustment and initial operation sequence

(As the instruction mentioned below is intended for an initial operation after installation, please refer to (2) normal operation sequence for normal (usual) operation)

1. Turn on the main power switch on the front of the main body.  
Turn on the power switch on the front panel.
2. Set the desired temperature with the temperature controller on the front panel.
3. Put the hot melt adhesive into the tank. (Be careful not to mix any foreign substance )
4. It will take 30~40 minutes for the applicator to reach the set temperature.
5. Check the tank temperature with the tank thermometer on the front of the applicator.
6. Insert the hose electric connector to the socket on the back of the applicator main body.
7. Turn the select switch of motor part of the front panel to READY and press START button.  
(In case of READY, gas will not flow and it will rotate at 300 RPM)
8. Check that the solvent or dust is completely removed from the RETURN-side hose on the discharge can etc and only the hot melt adhesive is being discharged.  
And then stop the motor switch and turn off the power switch.
9. Connect the hose.
10. Make sure that pressure is not generated by turning anticlockwise the pressure control screw of Flow Control Valve (F.C.V).
11. Turn the knob of density controller clockwise fully.  
Note: Do not turn it if the temperature of applicator does not climb to the optimum temperature. Otherwise, density controller can be damaged.
12. Turn on the power switch of the applicator and set Select switch of motor part to READY and press START button. (Leave it idling for 5~10 minutes)
13. Open the valve of Nitrogen gas cylinder once and set the pressure (Mpa) of the regulator.
14. Set Select switch of motor part to RUN and turn on the gas switch.
15. Set the motor speed with knob. (          RPM)

16. Set pressure (            Kg/cm<sup>2</sup>) by adjusting Flow Control Valve (F.C.V)
17. Set the knob of the density controller to make the gas flow lamp flash repeatedly.  
This state indicates that the gas and the hot melt is well balanced.
18. Switch on GUN.
19. Check the foaming condition of the hot melt adhesive which has been applied.  
(Note) Measure the foaming rate by comparing the weight of the heat-resistant container which is filled with the hot melt before foaming and the weight of the heat-resistant container which is filled with the hot melt after foaming.
20. If the foaming rate (density) is low (insufficient gas), turn the knob of the density controller clockwise. If it is high, turn the knob anticlockwise.  
(Note) If you want to control a greater volume of gas than the density controller can accommodate, you have to reset the gas input volume from the gas meter on the front panel.  
(Note) Don't change motor speed at the SET UP condition. When you need to change motor speed, repeat the operation sequence from step 15.
21. Repeat step 19, 20 until you get the foaming rate you want.
22. Control gas pressure so that the gas flow lamp blinks rapidly when the applicator is discharging the required volume.  
(Note) ON or OFF signal should be not displayed on the gas flow lamp for long when the applicator is discharging normally. If it is displayed for long, it means that the gas pressure is set too high or too low.  
In order to get an optimum foaming condition, you have to set the gas pressure as low as possible in the normal discharge condition. When all the guns are at OFF condition for a long time, the occasional blinking of the gas lamp indicates that it is normal.  
(Note) Once you get the foaming rate you want, please control the discharge volume with Flow Control Valve (F.C.V). If you change the motor speed after it is determined, it will affect the foaming rate and you have to make an adjustment again from the beginning.  
(Note) The difference in the foamed hot melt does not necessarily mean the change of the foaming rate.  
  
\* If the gas flow lamp remains at ON or OFF condition for long, please open the drain valve and discharge the hot melt a little and use again after you confirm that the gas flow lamp returns to the normal condition.

- \* If you turn the knob of the density controller clockwise fully but you are still unable to get the foaming rate you want :  
replace the slug in the density controller with the one that has larger number of holes on it.
  - \* If you turn the knob of the density controller anticlockwise fully but you are still unable to get the foaming rate you want :  
replace the slung with the one that has smaller number of holes on it.

## 2) Normal operation sequence

### \* Normal start-up

1. Turn on the main power switch on the front of the main body.  
Turn on the power switch on the front panel.
2. Turn SELECT switch of motor part to READY and press START button.  
(Leave it idling for 5~10 minutes)
3. Open the valve of the Nitrogen gas cylinder.
4. Set SELECT switch of motor part to RUN and turn on the gas switch.
  - Circulate the hot melt until the density (foaming rate) is stabilized.
  - You can judge the stability of the density by the lighting of [GAS FLOW] lamp
5. Measure the foaming rate by discharging the hot melt adhesive from the gun.
6. Measure the discharge volume by discharging the hot melt adhesive from the gun.  
Adjust the pressure control valve (F.C.V) if necessary.
7. Foam melt system becomes ready if the foaming rate and the discharge volume of the hot melt adhesive are normal.

### \* Normal Stop

1. Turn the motor switch to STOP to stop the motor.
2. Set the gun for ON and release the remaining pressure slowly.
3. Close the gas cylinder.

## \* Refilling the Tank

1. Make sure that the hot melt is clean and no foreign substance is mixed.

Always keep the cover closed except when you add the hot melt to prevent it from becoming dirty or when you check the volume of the hot melt.

Be careful that no dust gets in when you put the additional hot melt into the tank.

Never try to put the hot melt directly from its sack. Keep the unused hot melt in a closed container.

2. Open the cover of the tank and fill up the tank with the hot melt.

Make sure that the hot melt does not spill over.

3. Close the cover.

- \* Check the volume of the hot melt in the tank regularly.

When the volume of the hot melt is reduced by more than half, fill the tank up to the level, 30cm below the top. This will result in less burning of the hot melt and any damage will be avoided by preventing the pump from idling.

## \* Changing the Hot Melt Adhesive

If you want to change the hot melt adhesive, you have to check with the manufacturer whether it is suitable. Clean the System completely with a neutral detergent before you put the new hot melt adhesive into it. Please consult the hot melt manufacturer for choosing the right detergent. Please follow the cleaning sequence as described in Chapter 6: Precautions and Inspections when you do the cleaning.

1. If the old hot melt adhesive and the new hot melt adhesive are not the ones that react to each other, reduce the level of the old hot melt adhesive until you can see the bottom of the tank. Then fill the tank with the new hot melt adhesive to the half line of the tank.
2. If the application temperature of the new hot melt adhesive should be higher than that of the old hot melt adhesive, reset the temperature control of the tank and the hose.
3. Turn the motor switch on the front panel to STOP and stop the motor.
4. Reduce the pressure by turning the pressure control screw of Flow Control Valve anticlockwise until the screw part protrudes by 18~20mm.
5. Disconnect the return hose from the pump block and place its end on the top of the waste container.
6. Start the motor by turning the motor switch.
7. Drain the hot melt adhesive into the waste container until the bottom of the tank appears.
8. Stop the motor and connect the return hose.
9. Fill the tank with the new hot melt adhesive and allow enough time until it melts.
10. Reset Flow Control Valve.
11. Stabilize the system by restarting the motor.
12. Switch on the gun and check whether the foaming rate and discharge volume of the foam melt is appropriate. If necessary, make adjustment of the applicator to get the right speed and the foaming rate as described in the operation sequence of Chapter 5, 1)Adjustment and initial operation sequence step 16~20.

(Note) You have to reset the density controller and Flow Control Valve if the rheology (fluid characteristic) of the new hot melt adhesive is greatly different from that of the old hot melt adhesive.

## 6. Precautions and Inspection

- \* Operation should be allowed only to those persons who have a full knowledge of electricity.
- \* Never fail to remove the pressure of the system to prevent burns by splattering hot melt adhesive when you open the connector having fluid pressure.

### 1) General

1. Keep the applicator clean always.
2. Keep the cover closed so that no dust or refuse gets in.

### 2) Regular

period	precautions and how to check
Every day (8 hours)	1. remove carbide or contaminant from the drain of the filter.
Every week (40 hours)	1. Check the connections of fluid pressure part, gas and electricity.
	2. Check the drive valve.
	3. Check the filter
6 months (1000 hours)	1. Check the motor brush
	2. Change the filter
	3. Clean the whole system with an appropriate detergent
	4. Check that light of the front panel is working properly

### 3) Cleaning of the adhesive filter

1. Set the stopper on OFF position on the pump block
2. Disassemble the density valve and clean it and reassemble

### 4) Checking the connections of fluid pressure, gas and electricity

1. Pay attention to the connections between the hose and the gun and to the connectors and fittings of the pump block and check whether there is no leakage or damage.
2. Check that the gas tube is not bent or constricted.
3. Check that the electrical connections, wires and connectors are not Damaged.

## 7. Detailed specification of Model FBS-45

◇ Operating viscosity	:	50,000 CPS
◇ TANK capacity	:	45 Kg (99.2 lbs)
◇ MELT RATE	:	50 Kg / hr
◇ Maximum available temperature	:	normal - 230 °C (highest 250°C)
		( OPERATING TEMPERATURE RANGE )
◇ Temperature deviation	:	± 1 °C
◇ PUMP pressure	:	0 - 80 Kgf/cm <sup>2</sup> (MAX)
◇ HOSE quantity	:	1 - 4 EA (OPTIONAL)
◇ Electrical power	:	3P , 220VAC, MAX 41A, MAX 1.5Kw(MELT UNIT) 3N , 380VAC, MAX 31A, MAX 1.5Kw(MELT UNIT)
◇ MELT UNIT weight	:	150 Kg
◇ GAS	:	Industrial GAS , Carbon dioxide GAS
◇ MELT UNIT standard		

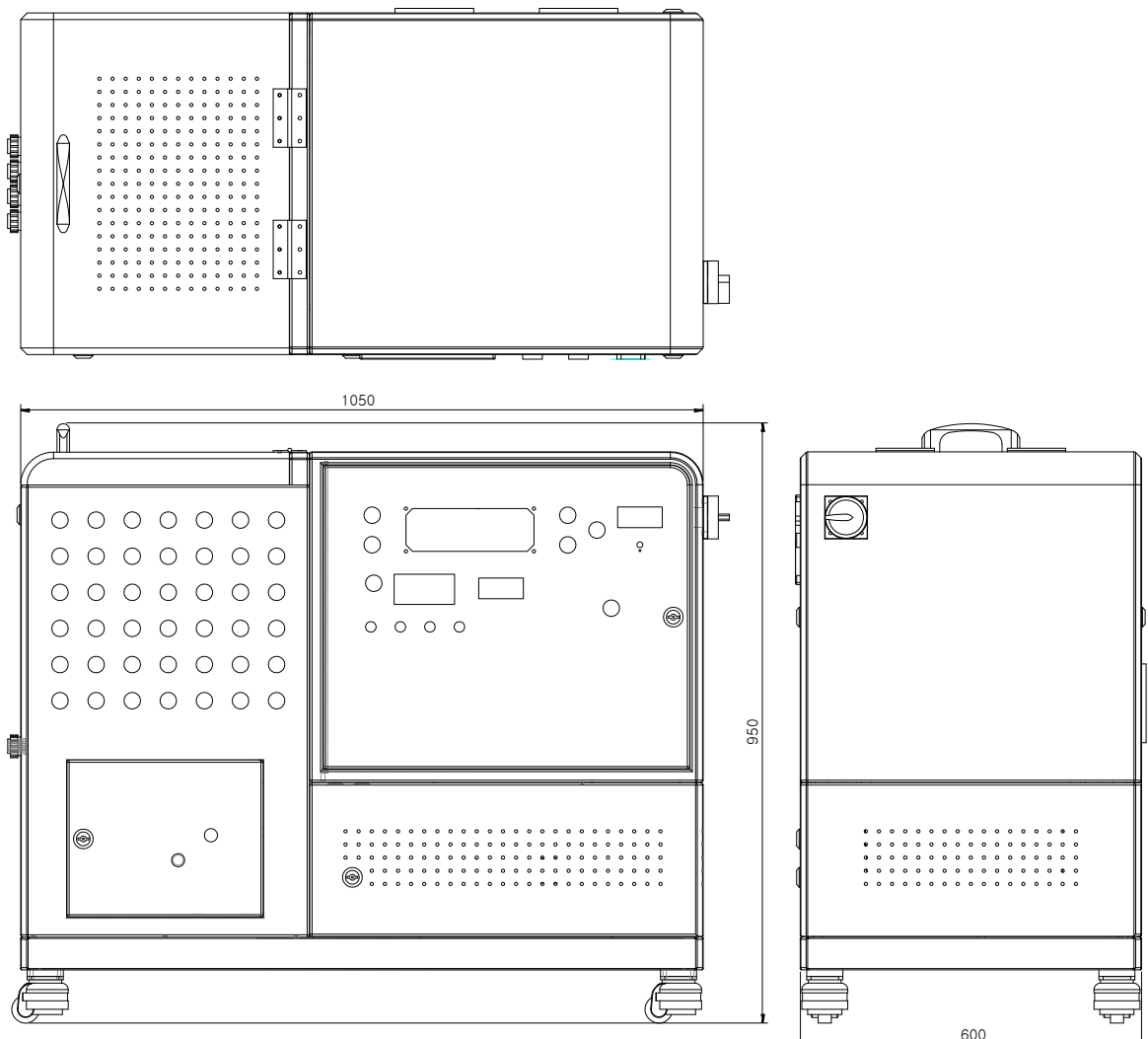

## 8-1. Explanation about various electrical parts

### ◆ TANK HEATER



#### ◆ HEATER standard

- o Rated voltage : 220 [VAC]
- o Caloric value (W) : 1000W x 6
- o Length (L) : 290 [mm]

### ◆ FILTER BLOCK HEATER



#### ◆ HEATER standard

- o Rated voltage : 220 [VAC]
- o Caloric value (W) : 1000W x 3
- o Length (L) : 290 [mm]

### ◆ MIDDLE GRID HEATER



#### ◆ HEATER standard

- o Rated voltage : 220 [VAC]
- o Caloric value (W) : 1200W x 3
- o Length (L) : 240 [mm]

### ◆ RTD SENSOR



#### ◆ SENSOR SPEC'

- o Type : PT TYPE
- o Length (L) : 30 [mm]

### ◆ TERMINAL

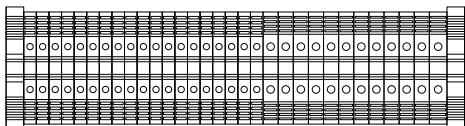

#### ◆ TERMINAL standard

- o MAIN TERMINAL
  - Voltage : 600 [VAC]
  - Current : 40 [A]
- o SPARE TERMINAL
  - Voltage : 600 [VAC]
  - Current : 20 [A]

### ◆ S . S . R

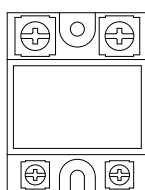

#### ◆ TANK S.S.R 规格

- o Input voltage : 3 - 32 [VDC]
- o Output voltage : 240 [VAC]
- o Current : 50 [A]

◆ MAIN SWITCH

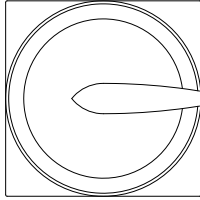

◆ MAIN SWITCH standard

- o Voltage : 220 [VAC]
- o Current : 20 [A]
- o Type : MS TYPE

◆ TANK FILTER



◆ FILTER standard

- o 60 MASH

◆ LAMP

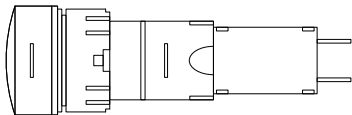

◆ LAMP standard

- o Voltage : 220 [VAC]
- o Color : White, Green

◆ OVERTEMP SWITCH

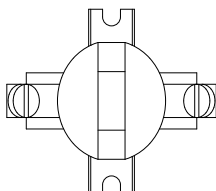

◆ OVERTEMP SWITCH

- o It turns off when overheated in 450°F (highest temperature 485°F)
- o With S/W Off, power supply is cut off from TANK HEATER. When safety is ensured with temperature down, S/W is turned on.
- o Used in preventing TANK from being overheated.

◆ RELAY

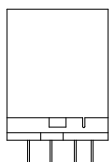

◆ RELAY

- o When OPERATION SIGNAL comes in, it is used as contact point.(Role of starting motor)
- o Voltage : 220 [VAC]

◆ TEFRON WIRE

◆ TEFRON WIRE

- o Teflon wire resistant to high temperature.

## 8-2. Specification and features of motor

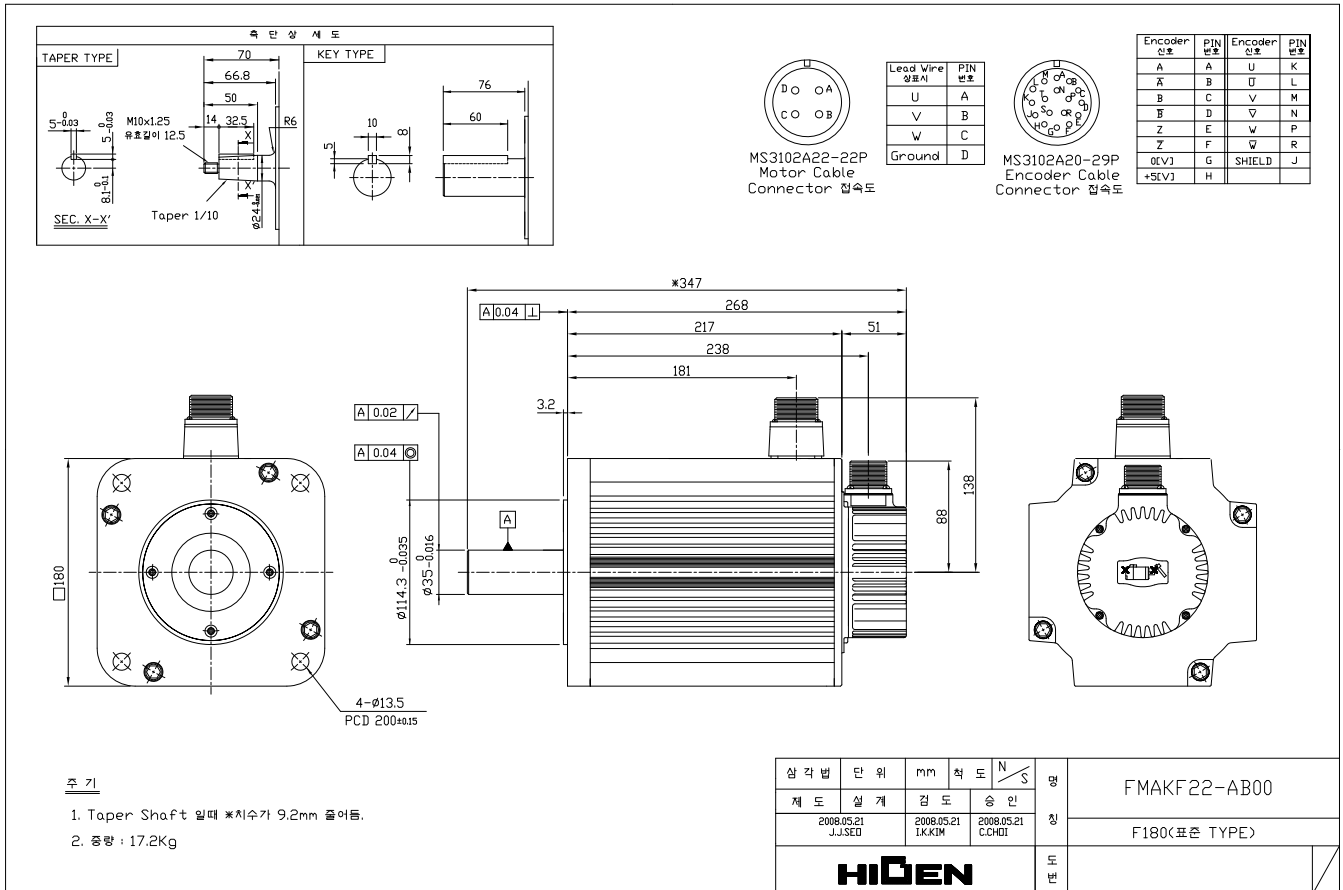

- o Rated voltage : 3Ø 220 VAC
- o Rated current : 14.1[A]
- o Number of revolution : 2000 r.p.m
- o Frequency : 50~60 Hz
- o Rated output : 2000W

- ◇ Care to be taken that single-phase geared motor not be overloaded while being used.
- ◇ Motor should not be rotated until temperature for safe operation of the machine is reached.
- ◇ Hot melt should be molten enough to enable motor to rotate.
- ◇ Motor should use rated voltage and rated current.

## 9. PART LIST

(1) Disassembly drawing and explanation for FBS TANK

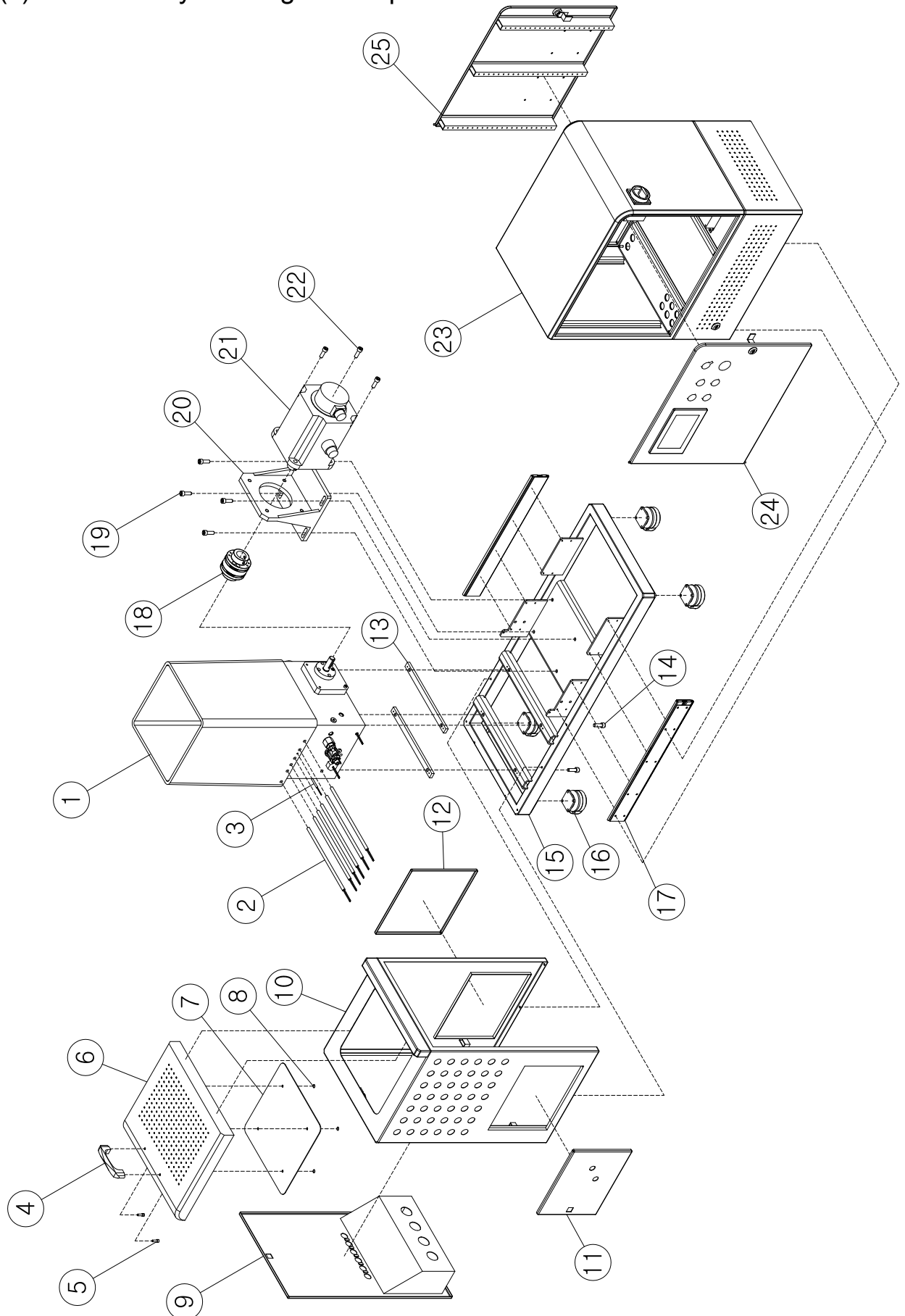

◆ Disassembly drawing and explanation for FBS TANK

NO	Q'TY	PART / NO	CONTENT / SPEC'
1	1	981101	ASS'Y TNAK & PUMP BLOCK
2	6	222202	HEATER (3/8" x 220V x 800W x 300L)
3	1	710405	SENSOR (PT TYPE)
4	1	981102	GRIP
5	2	412152	WRENCHI BOLT (M6x10L)
6	1	981103	TNAK TOP COVER
7	1	981104	TANK IN PLATE
8	4	981105	E-RING (#4)
9	1	981106	HOSE COVER
10	1	981107	TANK COVER
11	1	981108	SIDE OP COVER
12	1	981109	SIDE COVER
13	4	981110	PEBIT
14	4	412153	WRENCHI BOLT (M10x20L)
15	1	981111	BASE FRAME
16	4	981112	FOOT
17	2	981113	SLIDE RAIL
18	1	981114	COUPLING
19	4	412154	WRENCHI BOLT (M10x25L)
20	1	981115	MOTOR BRACKET
21	1	981116	MOTOR
22	4	412155	WRENCHI BOLT (M12x35L)
23	1	981117	ASS'Y EL BOX
24	1	981118	SIDE COVER LCD
25	1	981119	SIDE COVER

(2) Disassembly drawing and explanation for PUMP BLOCK

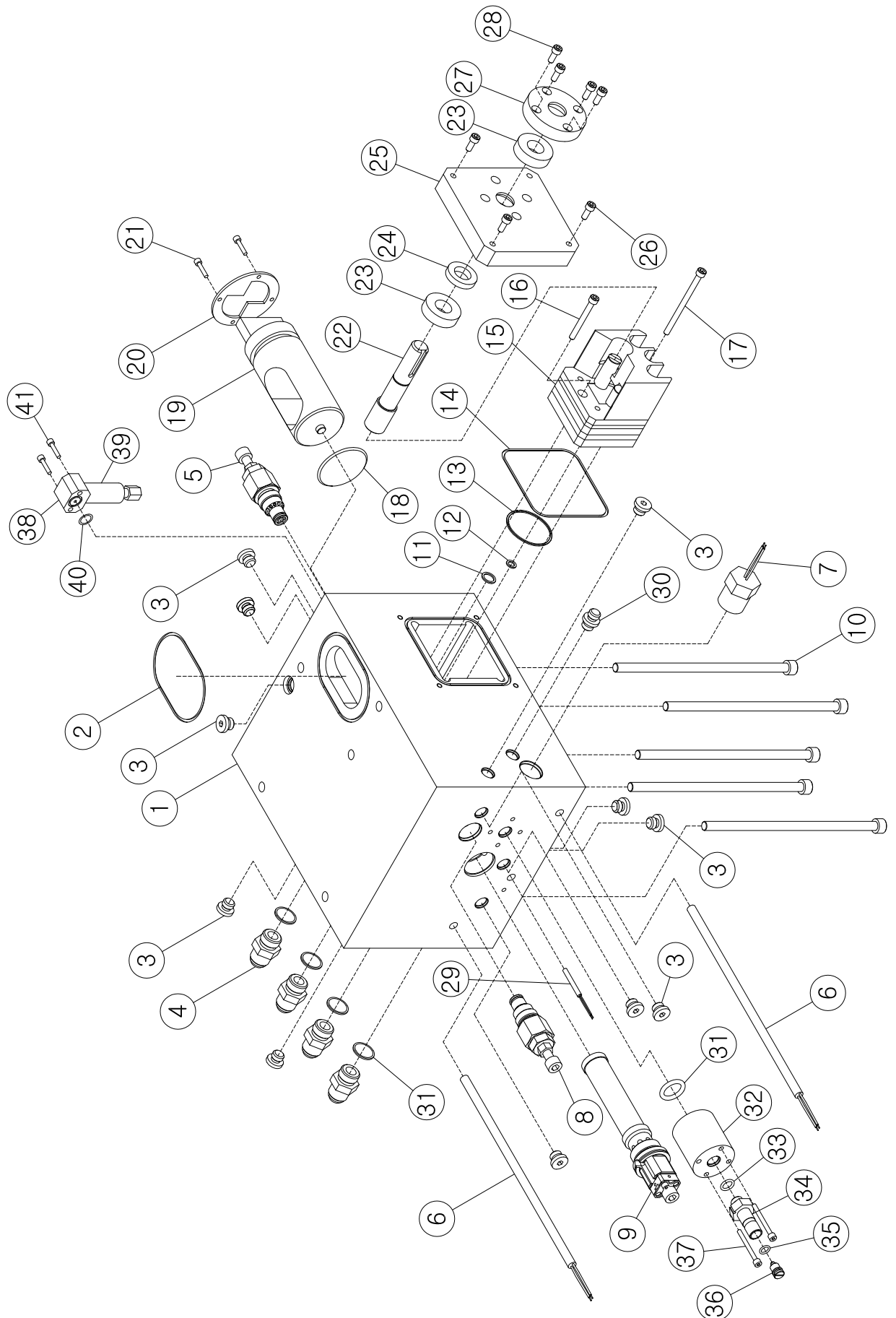

◆ Disassembly drawing and explanation for PUMP BLOCK

NO	Q'TY	PART / NO	CONTENT / SPEC'
1	1	981120	FILTER BLOCK
2	1	523102	O-RING (AN153)
3	11	461102	BLANK (PS 1/4")
4	4	471206-2	HOSE NIPPLE (UNF 7/8"-14)
5	1	981121	RELIFE VALVE ASS'Y
6	3	222203	HEATER (3/8" x 220V x 800W x 280L)
7	1	981122	PRESSURE SENSOR (PT1")
8	1	981123	F.C.V VALVE ASS'Y
9	1	981124	DENSITY VALVE ASS'Y
10	5	412156	WRENCHI BOLT (M10x190L)
11	1	523014	O-RING (AN014)
12	1	523011	O-RING (AN011)
13	1	523033	O-RING (AN033)
14	1	523106	O-RING (AN157)
15	1	981125	F/M PUMP ASS'Y
16	5	412105	WRENCHI BOLT (M6x50L)
17	1	412157	WRENCHI BOLT (M6x90L)
18	1	522045	O-RING (P50A)
19	1	981126	STOPPER
20	1	981127	POSITION PLATE
21	4	412137	WRENCHI BOLT (M4x10L)
22	1	981128	DRIVE SHAFT
23	2	981129	BEARING (KB6004ZZ)
24	1	981130	OIL SEAL-VITON (20x35x7)
25	1	981131	P & B COVER



(3) Disassembly drawing and explanation for DENSITY VALVE

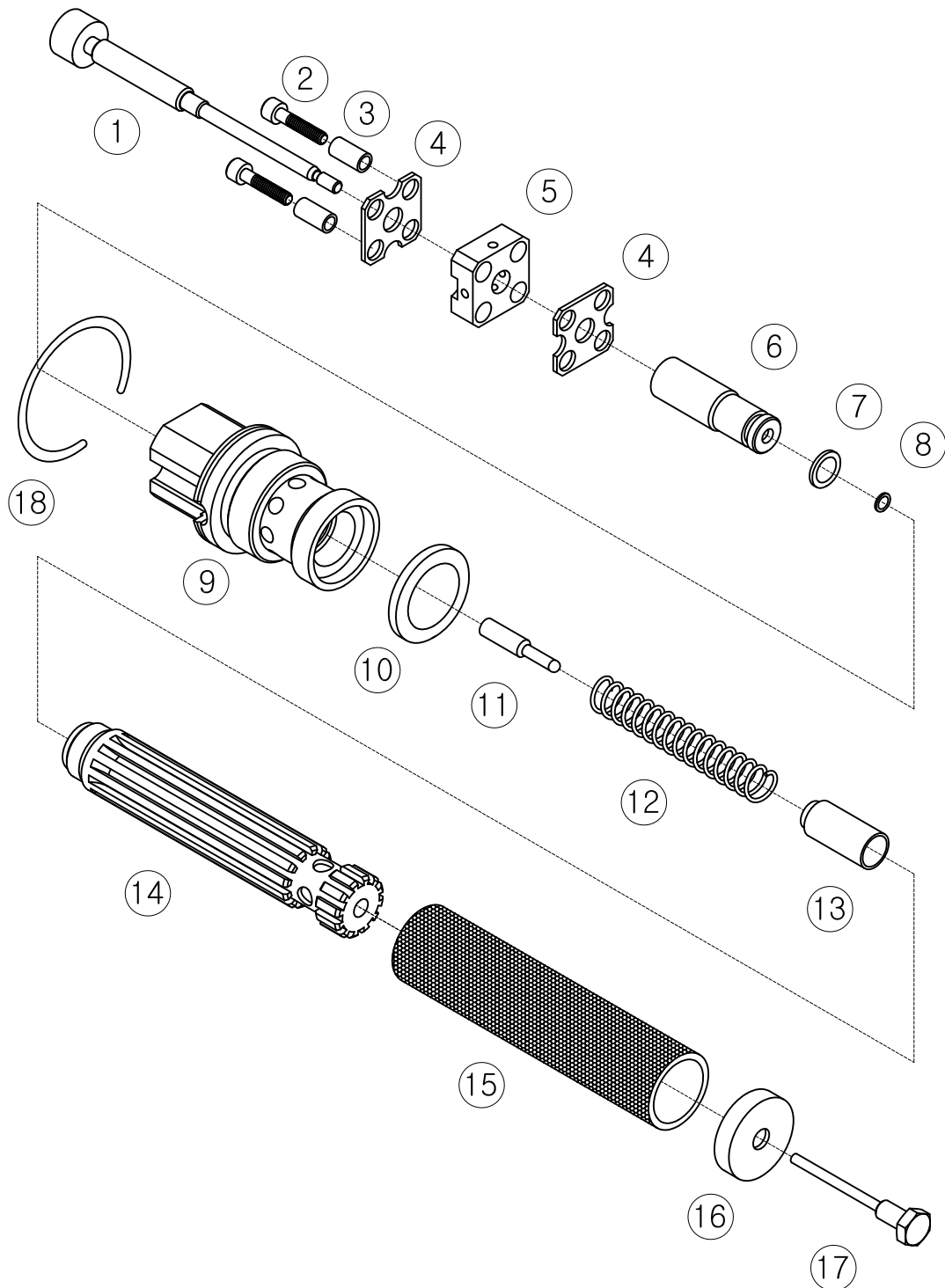

◆ Disassembly drawing and explanation for DENSITY VALVE

NO	Q'TY	PART / NO	CONTENT / SPEC'
1	1	981138	ROD
2	4	412135	WRENCHI BOLT (M4x20L)
3	4	981139	INSULATOR TBBE
4	2	981140	INSULATOR PLATE
5	1	981141	CONTACTOR
6	1	981142	BODY INSULATOR
7	1	523012	O-RING (AN012)
8	1	523008	O-RING (AN008)
9	1	981143	BODY
10	1	523073	O-RING (AN124)
11	1	981144	ROD BALL
12	1	981145	SPRING DENSITY
13	1	981146	SLUG
14	1	981147	CORE
15	1	981148	FILTER ( MESH)
16	1	981149	FILTER CAP
17	1	981150	SLUG STOPPER
18	1	981151	WIRE RING

(4) Disassembly drawing and explanation for F.C.V VALVE

